



Instruction manual for your wireless system

Bench test all components before permanently mounting

Helpful videos to get you started



Full installation guide for your wireless backup camera system



Insert shell removal video



Plastic screen protector film removal

Where to start?

Stage 1 - Setting up the monitor side:

1. Remove the monitor and all its cables from the box
2. Connect the monitor to the dash mount and adjust (to expose the groove, you might need to remove the outer shell)
3. Connect the harness to the corresponding plug in the monitor.
4. Take the receiver (R) and connect it to the corresponding RCA and Red barrel connector of the monitor harness
5. Screw in the black antenna to the receiver (R)
4. On the monitor harness Connect the red (+) and black (-) bare wires to your 12-volt power source
TIP: if you purchased the cigarette adapter, use that now
5. Turn on the monitor and you should see either an LED light or a blue screen saying “No Signal”.
(Don't worry about the “No Signal” it will disappear as soon as you connect the camera)

Stage 2- Setting up the camera side:

1. Remove the Backup camera from the box with all its cables.
(We always recommend testing the camera before mounting it)
2. Connect the RCA and red barrel connector coming off the camera to the transmitter (T)
5. Screw in the black antenna to the transmitter (T)
3. Connect the red (+) and black (-) bare wires coming off the transmitters to your 12-volt power source
TIP: if you want the camera on while you're driving, connect it to a constant power source such a running light, otherwise use the reverse light.
4. Mount the camera in its designated location (Roof, License plate, Bumper, etc...) and make sure it is getting power by check the small red LED on the transmitter
TIP: if you're using a split screen adapter, repeat stage 1 and 2 on each transmitter and receiver
(make sure each letter is different A,B,C,D for each transmitter and receiver)
5. if you follow these steps you should see the cameras image on your screen, if not, verify that you are on the correct channel input



Diagram of connections for a wireless system

Bench test all components before permanently mounting

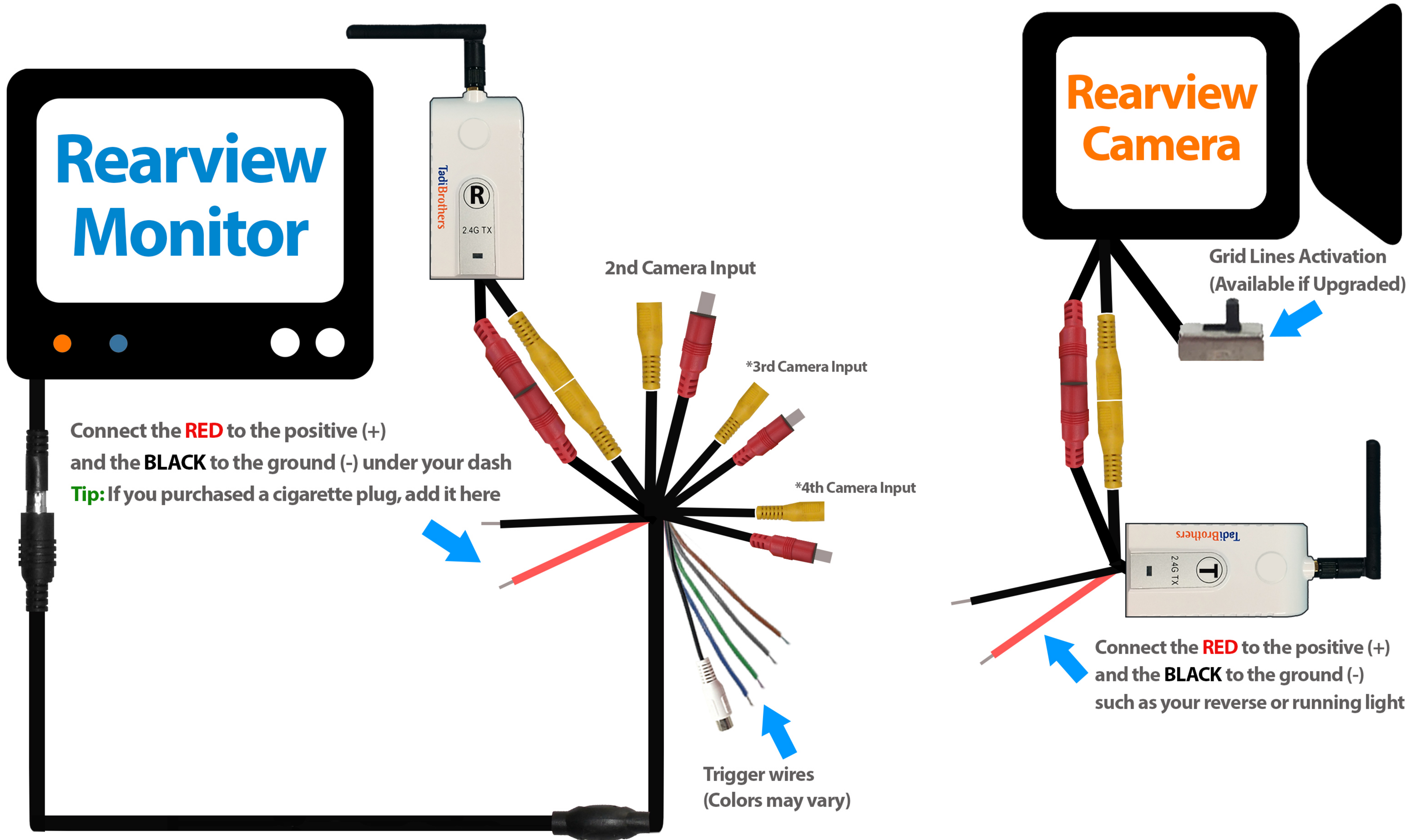

*3rd and 4th inputs are available only if you purchased split screens

Tips that might help



If your system came with a monitor 7-inches and above and you can't see the mounting groove for your bracket, you might need to remove the dash "insert shell".

To remove the shell, press down on the two buttons/tabs on the sides of the monitor, then press down on the little red tab on by the bottom corner of the screen. Then remove the monitor from the shell.

To test that your camera is getting power or to see if your night vision is active, place your hand over the camera and look for the LED lights that surround the lens to turn red. This process will work with ANY of our back-up camera that have the LED lights around the lens (i.e. license camera, RV camera, Bumper camera etc....)

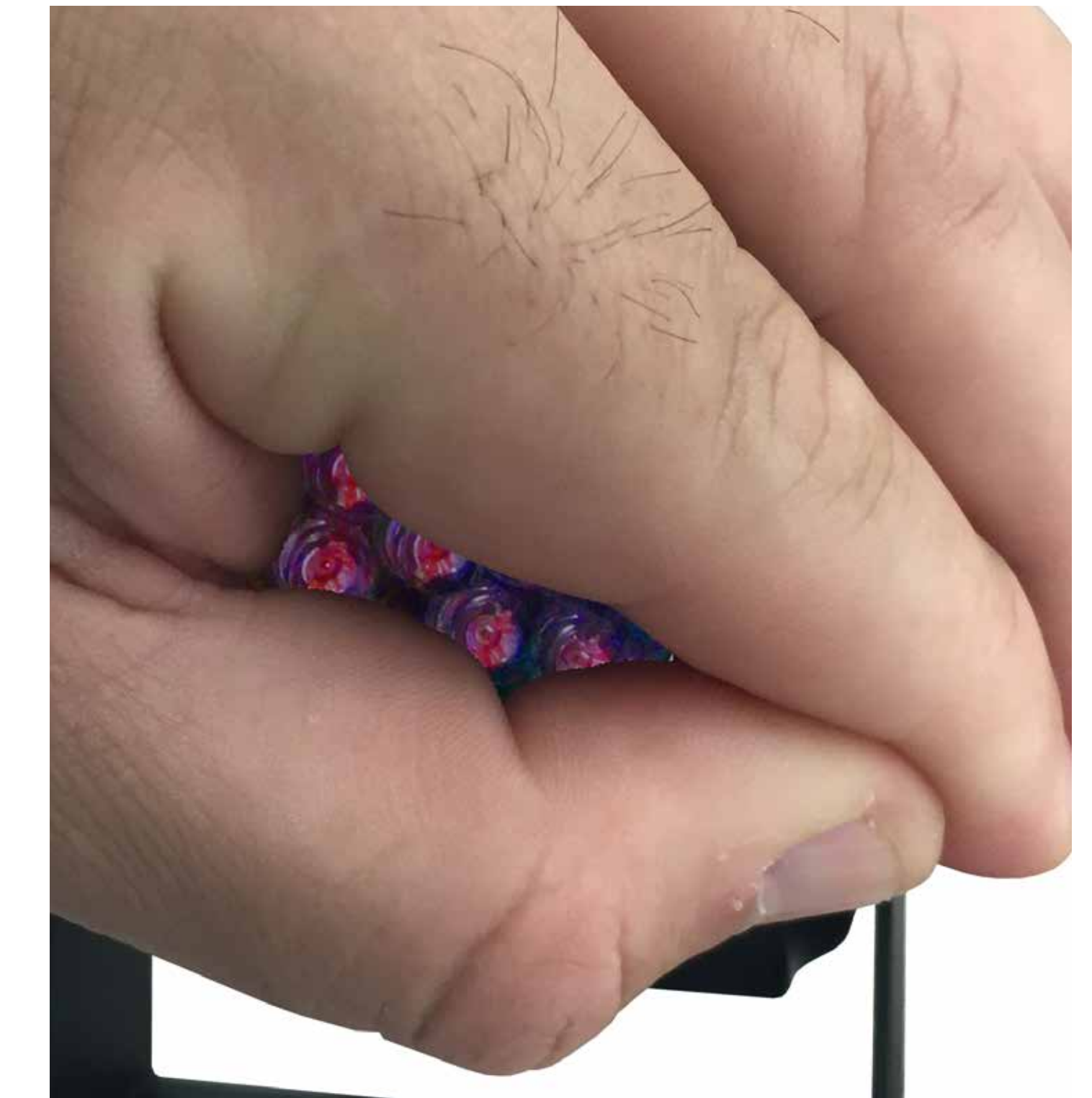

NOTE: LED Lights may be very faint (they are meant to soak in light)

4 Channel Remote



Power on/off

Enter the menu to change the monitor settings

Navigate through the settings

Change camera channels 1-4

2 Channel Remote



Power on/off

Switch between Video 1 and Video 2

Navigate through the settings

Change screen resolution

Mounting Examples of Cameras



Connect both bare wires to the reverse light or any constant power source



Transmitter is usually placed **BEHIND** the bumper
(Don't worry it's 100% water and weather proof)



Mounting Examples of Monitors



Mounting Ideas:
Give your monitor an overhead view by flipping the dash mount that came with your monitor.



You can also get the overhead view with our **suction cup** by mounting it up high.

Receiver Mounting Ideas:
When mounting the Receiver most people bury it with all the cables under the dash. However, if you want it out, we recommend velcroing it to the back of our monitors

(This image is only an example, velcroing can be done to ANY of our monitors)



Extra Mounting Advice

The transmitters does NOT need line of site and can be hidden anywhere, some people have even put them in their rear closet. (Yes it is still 100% water proof if you want to leave it outside)



Pick an easy spot near a 12 volt power source and angle the camera to the desired view

Cameras Connected to the Transmitter



Example of a Split Screen Setup

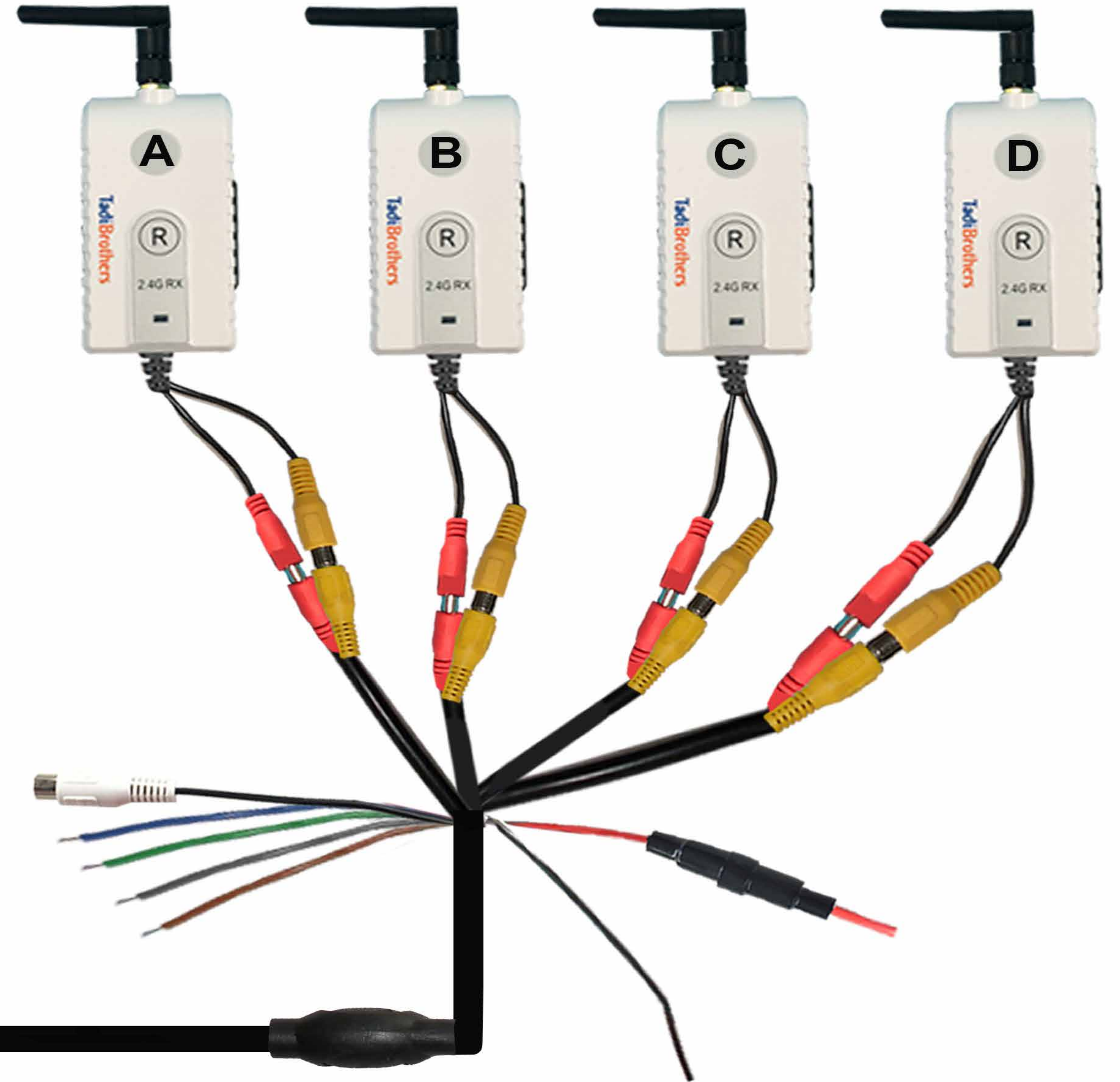

Troubleshooting Guide Page 1

These are common issues and questions we have compiled, please read through them and see if they answer any of your questions.

Caution: To avoid burning out your back up camera system you **MUST** connect the camera to the transmitter **BEFORE** connecting the transmitter to the power of the vehicle power/Battery.

1. Why don't the LED lights on the camera turn on?

A. The led bulbs you see on your camera are (infrared) they are meant to soak in the light. When that camera is powered you should not see any lights

2. Why do I see "NO SIGNAL" on my monitor?

A. This means that the monitor is not getting a picture from the camera, make sure the camera is connected to the power and if you are using a wireless system double check that the adaptors are both getting power.
B. If this still doesn't work try connecting the camera directly to the monitor so that you can see if the problem is with the wireless adaptors, the cables between the monitor and the camera, or the camera itself

3. Why is my monitor showing white?

A. This is usually a result of using a bad power connector, make sure ALL the cables are insulated correctly and don't use any "makeshift" cigarette adaptors. Those may use more than 14 volts and will cause the system to go white or even burn it out.

4. How can I get an original cigarette adaptor?

A. You can purchase it at tadibrothers.com (SKU89171) or take the cable to your local Radio Shack and they should have what you need.

5. Why does my screen look "scratched up"?

A. Peel off the film over the screen, even if it looks like it's not there, keep trying, we don't sell used items and its ALWAYS the film over the screen (This only applies to MONITORS not MIRRORS)

6. Where can I have it installed?

A. You can install your system anywhere that installs car radios; it should not take more than 1-2 hours of work. Some of our customers have had success with Best Buy.

7. How can I connect my system so that it is always on?

A. When installing the camera plug it into a constant power source (a power source that is always on, when the vehicle is on) then you will always be able to look behind.

8. How do I connect my system so that it turns on when I go in reverse?

A. When installing the camera, connect it to a reverse light power source this way the camera will turn on only when you go in reverse, and the monitor will show an image only when it is getting a picture from the camera. (Note: The RED wire connects to the positive (+) of the reverse light & the BLACK wire connects to the ground (-) of the reverse light)

Troubleshooting Guide Page 2

9. What is the pass code for my Bluetooth monitor?

We have 3 codes that you should try:

- A. 0000
- B. 1234
- C. 8888

10. My system is supposed to be wireless, why are there so many wires in a wireless system?

A. The reason your system is called wireless is because there is NO WIRE between the monitor and the camera, both systems still need power/ground and a wireless module

11. Why are there NO holes or groves for my monitors dash mount stand?

A. Remove the plastic shell that is over your monitor, it might look like it's part of the monitor but it can pop off, when you pull on it you can see that it can be taken off

12. My 2.5-4.3" Monitor doesn't show anything but a black screen?

- A. Your camera isn't getting power
- B. The RCA cable is not plugged in to both sides correctly
- C. One or both of you wireless adaptors are not power up (check connections)

13. Why is there a Blue or Green wire, what do I do with it?

A. The Blue or Green Cable is an optional trigger wire for the monitor, if connected to reverse fuse (usually under your dash) the monitor will activate when you go in reverse

14. Do the transmitter boxes need to be protected from the weather?

A. No, they are weather proof, but we do recommend setting them up so that they won't dangle while you drive, this way you get a clearer image and they won't get damaged from bouncing around.

15. Why does my wireless system lose reception when I drive or when I turn on the vehicle?

- A. Try connecting the wireless adaptors to a different power source, there have been rare cases that power source caused interference
- B. Try extending the transmitter with an RCA cable so that its closer to the receiver (some areas have more interference than other so it needs that extra boost)

16. My wireless system gets lines or "no signal" in the display only when I start driving?

A. Make sure the wireless adaptors are fastened tightly to the vehicle and not bouncing around.
(Tip - use Velcro to fasten them to the vehicle, available at Tadibrothers.com or most stores)

17. How do I remove the grid lines from my camera?

A. To remove the gridlines, twist together the two wires that come out of the camera, only then, connect the power plug into the 12 volt of the vehicle or battery, then the lines will disappear.

18. How can I return my product?

A. All items must get an RMA from our service department, please call them for the RMA at 866-966-5550 X 2

